

STANLEY
Access Technologies

DURA-STORM
3000
"LEVEL D"
IMPACT SERIES

BI-PARTING PROJECT INFORMATION	
PROJECT NAME:	
LOCATION:	
DOOR NUMBER(S):	
DATE:	SHEET: OF

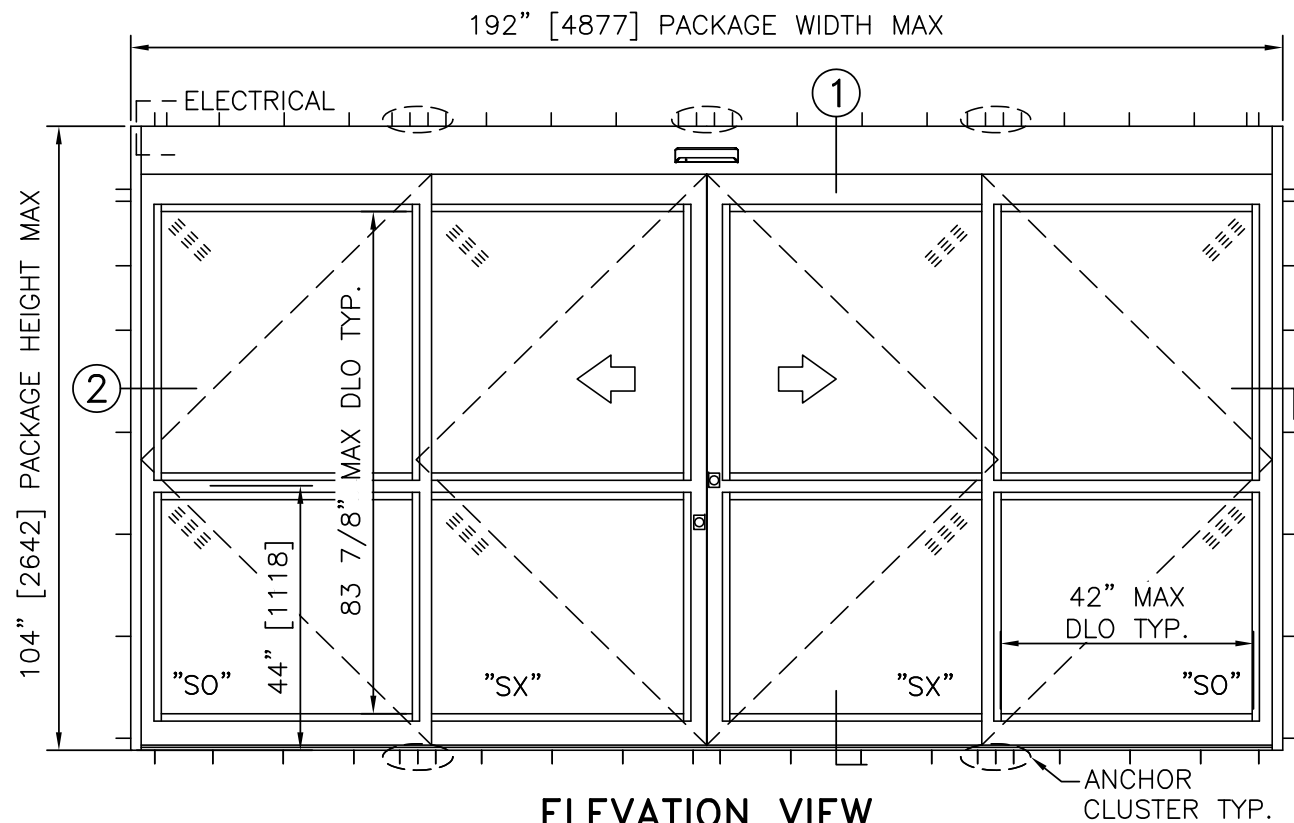

ELEVATION VIEW
SCALE: 3/8" = 1'-0"

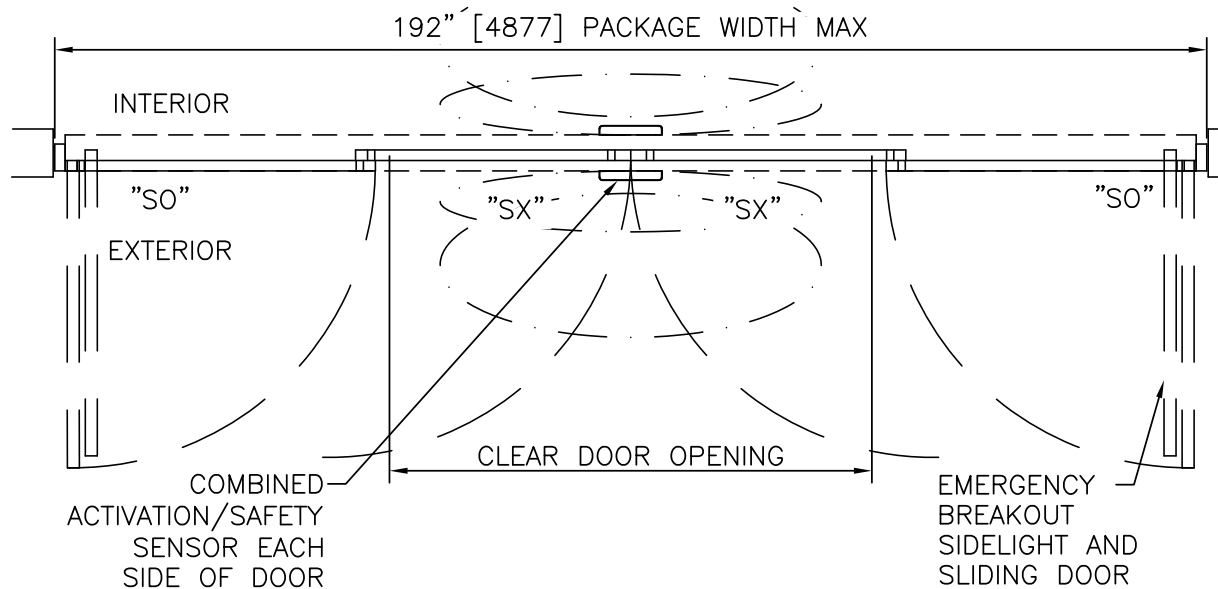

1 VERTICAL SECTION
SCALE: 2" = 1'-0"

BI-PARTING FORMULAS - NARROW STILE
 PACKAGE WIDTH = 2 X CLEAR DOOR OPENING + 26.50"
 CLEAR DOOR OPENING = 1/2 PACKAGE WIDTH - 13.25"
 EMERGENCY BREAKOUT WIDTH = PACKAGE WIDTH - 14.50"
 SX DOOR PANEL WIDTH = 1/4 PACKAGE WIDTH - 0.53"
 SO DOOR PANEL WIDTH = 1/4 PACKAGE WIDTH + 0.16"

BI-PARTING FORMULAS - MEDIUM STILE
 PACKAGE WIDTH = 2 X CLEAR DOOR OPENING + 35.25"
 CLEAR DOOR OPENING = 1/2 PACKAGE WIDTH - 17.63"
 EMERGENCY BREAKOUT WIDTH = PACKAGE WIDTH - 17.5"
 SX DOOR PANEL WIDTH = 1/2 PACKAGE WIDTH + 1.44"
 SO DOOR PANEL WIDTH = 1/2 PACKAGE WIDTH + 1.44"

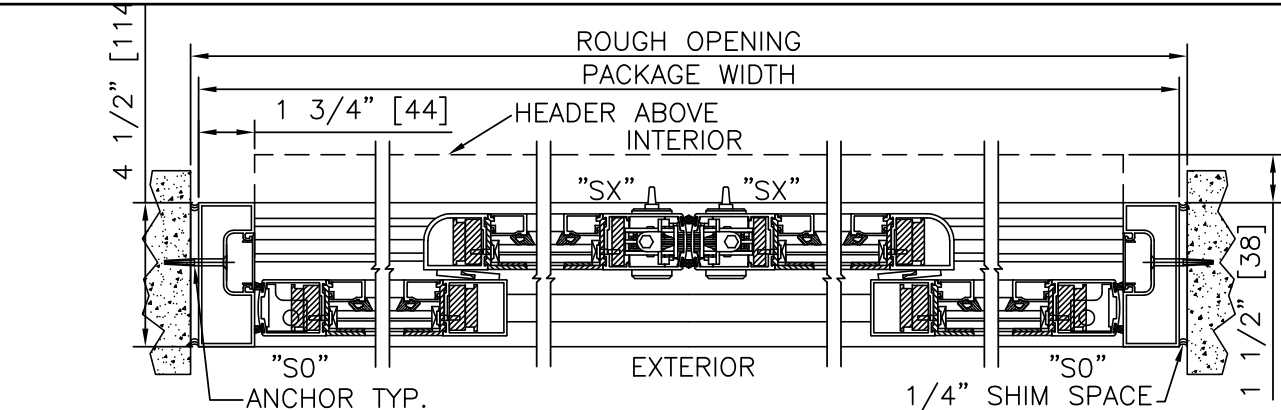

2 HORIZONTAL SECTION
SCALE: 2" = 1'-0"

PRODUCT OPTIONS

- FINISH**
- ANODIZED CLEAR CL2
 - ANODIZED DK BRONZE
 - CUSTOM
- LOCKING**
- 5-POINT
 - 4-POINT W/ PANIC RELEASE
 - ELECTRIC SOLENOID LOCK
- STILES**
- NARROW MEDIUM
- MUNTINS**
- 2" 4 1/4"
 - NONE
- JAMBS**
- 4 1/2" 6"
- BOTTOM RAILS**
- STANDARD 4"
 - OPTIONAL 6" 8" 10"
- THRESHOLDS**
- SQ/BVL (EXT) SQ/BVL (INT)
 - DBL BVL RECESSED
- ACTIVATION/SAFETY**
- 2 COMBINED ACTIVATION/SAFETY SENSORS
- OTHER OPTIONS**
- ROTARY CTRL SWITCH KEYED
 - UNINTERRUPTIBLE POWER SUPPLY
 - FLY OPEN BOX
 - WIND DAMPERS
 - ALARM CONTACTS

MAX. PACKAGE DIMENSIONS (NARROW STILE)				
PACKAGE WIDTH	NOMINAL CLEAR DOOR OPENING	SO DOOR PANEL NOMINAL WIDTH	SO DOOR PANEL NOMINAL WIDTH	EMERGENCY BREAKOUT NOM. WIDTH
192"	82.3"	48.5"	48.1"	177.5"

DESIGN RATINGS	
MISSILE IMPACT RATING	
<input checked="" type="checkbox"/>	LARGE MISSILE IMPACT
<input checked="" type="checkbox"/>	IMPACT, 50 FT/S, "LEVEL D"
DESIGN PRESSURE RATING (PSF [Pa])	
POSITIVE	80 PSF [3830 Pa]
NEGATIVE	80 PSF [3830 Pa]

- NOTES**
- ELECTRICAL REQUIREMENTS: 120 VAC, 5 AMP MIN TO POWER OPERATOR BY ELECTRICAL CONTRACTOR.
 - ROUGH OPENING SHALL PROVIDE 1/4"[6] SHIM SPACE ON SIDES AND TOP OF PACKAGE.
 - ACTIVATION AND SAFETY ZONES ARE FOR REFERENCE ONLY; SEE ANSI/BHMA A156.10 FOR DETAILED REQUIREMENTS.
 - 3-POINT LOCKING STANDARD, 2-POINT LOCKING WITH PANIC RELEASE OPTIONAL. ELECTRIC SOLENOID LOCK MAY BE ADDED FOR ACCESS CONTROL.
 - ENTRANCE TO RECEIVE APPROVED 9/16"[14] LAMINATED, OR 1 1/8"[29] LAMINATED/INSULATED GLASS, AND DRY GLAZING.
 - STANDARD STILES, BOTTOM RAILS AND MUNTINS SHOWN; MEDIUM STILES, BOTTOM RAILS TO 10"[254], AND 4 1/4"[108] MUNTINS AVAILABLE.
 - PRODUCT SHALL BE MANUFACTURED AND INSTALLED IN ACCORDANCE WITH PRODUCT APPROVALS; SEE MIAMI-DADE COUNTY NOTICE OF ACCEPTANCE OR FLORIDA BUILDING CODE APPROVAL
 - SEE SPECIFICATIONS FOR ADDITIONAL INFORMATION.

BI-PARTING

DURA-STORM
3000
"LEVEL D"
IMPACT SERIES

STANLEY
Access Technologies

**DURA-STORM
3000
"LEVEL D"
IMPACT SERIES**

BI-PARTING

PROJECT INFORMATION

PROJECT NAME:

LOCATION:

DOOR NUMBER(S):

DATE:

SHEET: OF

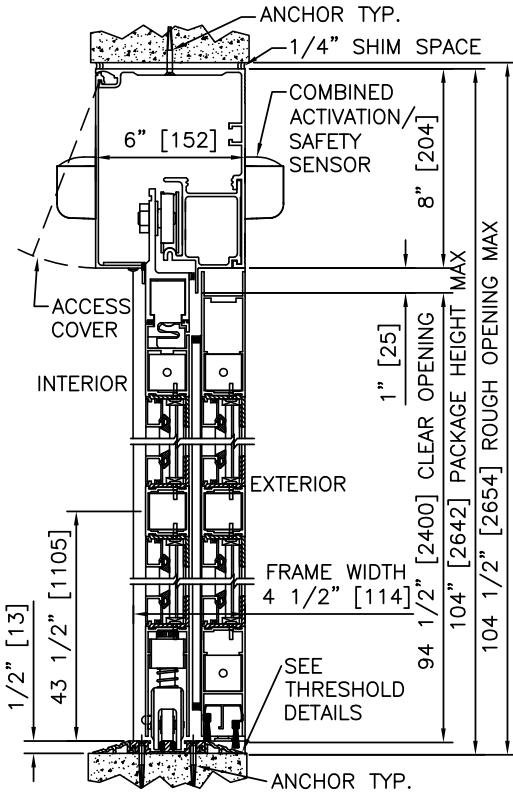

① VERTICAL SECTION

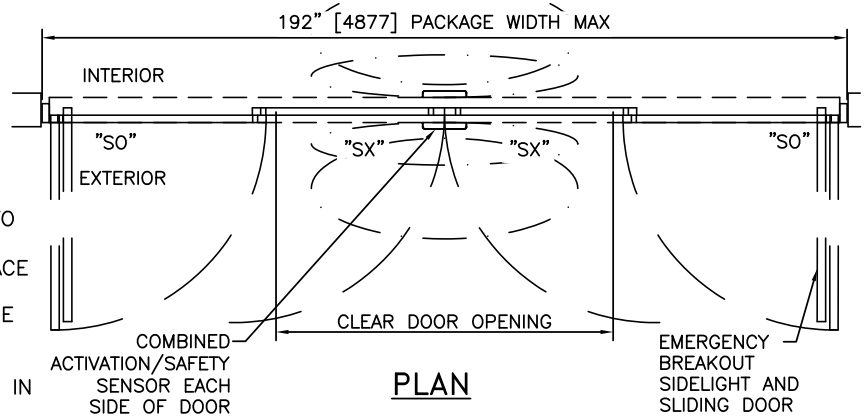
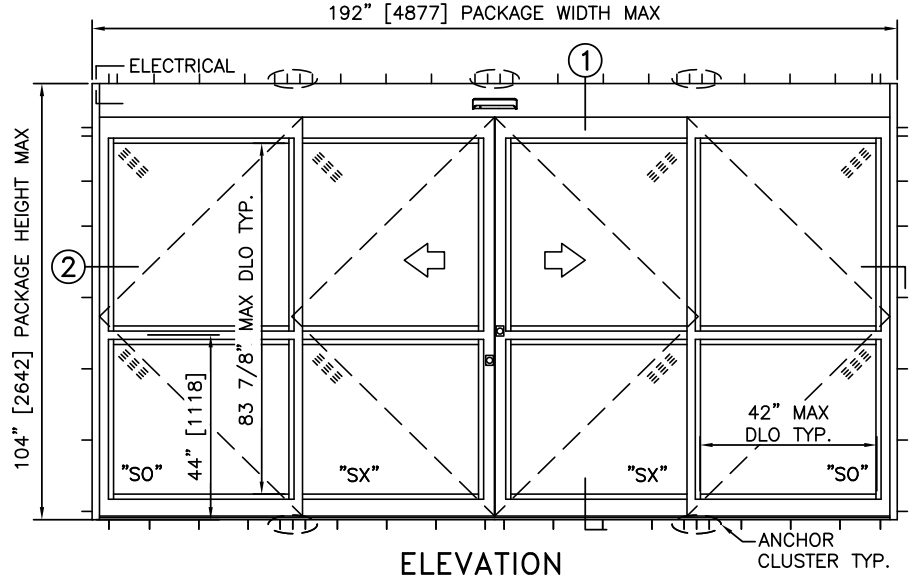

NOTES

1. ELECTRICAL REQUIREMENTS: 120 VAC, 5 AMP MIN TO POWER OPERATOR BY ELECTRICAL CONTRACTOR.
2. ROUGH OPENING SHALL PROVIDE 1/4"[6] SHIM SPACE ON SIDES AND TOP OF PACKAGE.
3. ACTIVATION AND SAFETY ZONES ARE FOR REFERENCE ONLY; SEE ANSI/BHMA A156.10 FOR DETAILED REQUIREMENTS.
4. PRODUCT SHALL BE MANUFACTURED AND INSTALLED IN ACCORDANCE WITH PRODUCT APPROVALS; SEE MIAMI-DADE COUNTY NOTICE OF ACCEPTANCE OR FLORIDA BUILDING CODE APPROVAL
5. SEE SPECIFICATIONS FOR ADDITIONAL INFORMATION.

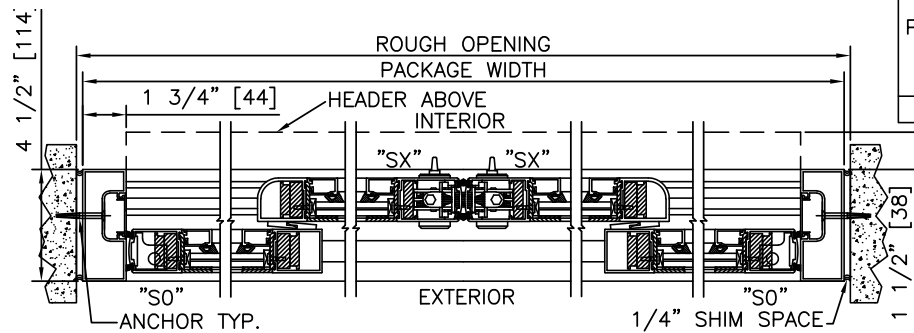

② HORIZONTAL SECTION

MAX. PACKAGE DIMENSIONS (NARROW STILE)				
PACKAGE WIDTH	NOMINAL CLEAR DOOR OPENING	SX DOOR PANEL NOMINAL WIDTH	SO DOOR PANEL NOMINAL WIDTH	EMERGENCY BREAKOUT NOM. WIDTH
192"	82.3"	48.5"	48.1"	177.5"

DESIGN RATINGS	
MISSILE IMPACT RATING	
<input checked="" type="checkbox"/>	LARGE MISSILE IMPACT
<input checked="" type="checkbox"/>	IMPACT, 50 FT/S, "LEVEL D"
DESIGN PRESSURE RATING (PSF[Pa])	
POSITIVE	80 PSF [3830 Pa]
NEGATIVE	80 PSF [3830 Pa]

**DURA-STORM
3000
"LEVEL D"
IMPACT SERIES**

BI-PARTING WITH PANIC RELEASE

PROJECT INFORMATION

PROJECT NAME:

LOCATION:

DOOR NUMBER(S):

DATE:

SHEET: OF

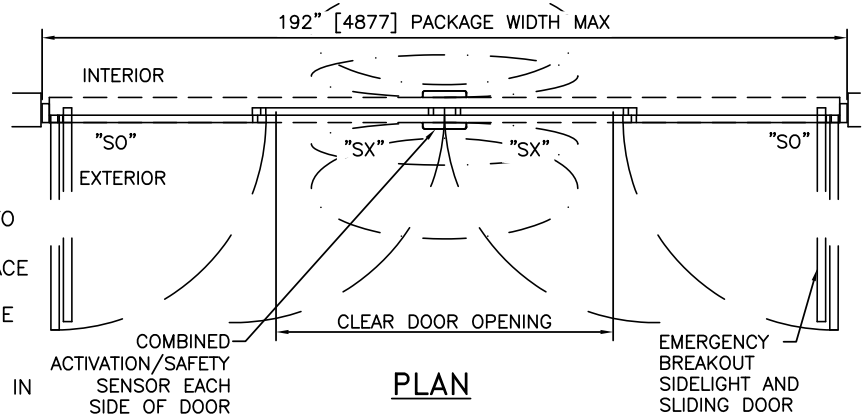
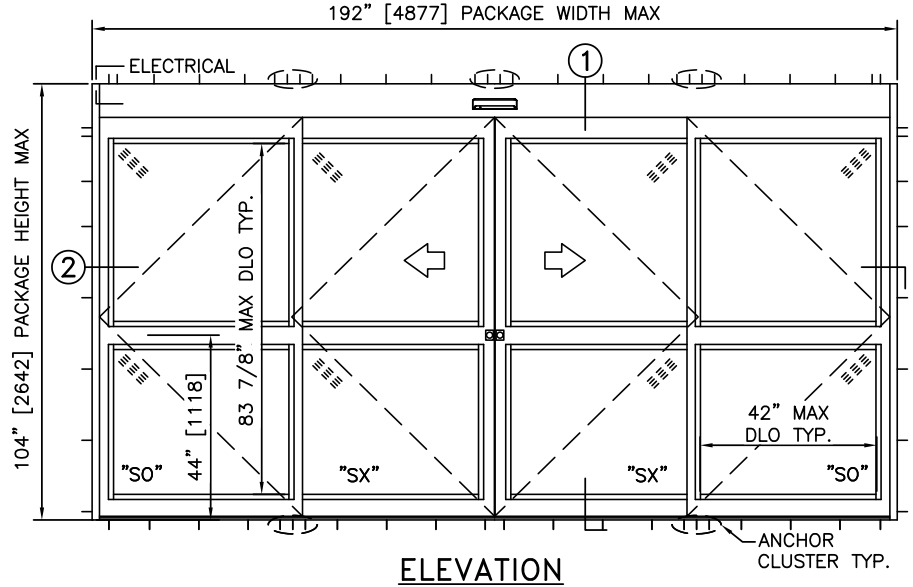
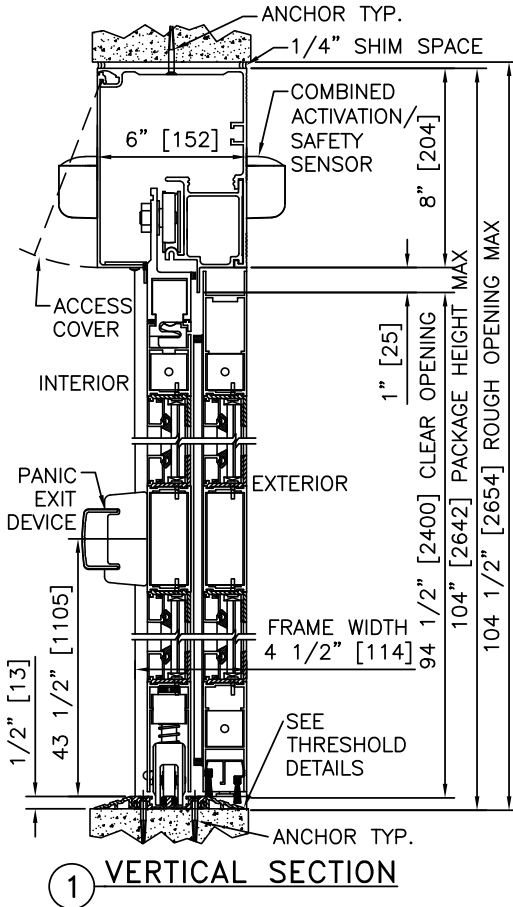

NOTES

1. ELECTRICAL REQUIREMENTS: 120 VAC, 5 AMP MIN TO POWER OPERATOR BY ELECTRICAL CONTRACTOR.
2. ROUGH OPENING SHALL PROVIDE 1/4"[6] SHIM SPACE ON SIDES AND TOP OF PACKAGE.
3. ACTIVATION AND SAFETY ZONES ARE FOR REFERENCE ONLY; SEE ANSI/BHMA A156.10 FOR DETAILED REQUIREMENTS.
4. PRODUCT SHALL BE MANUFACTURED AND INSTALLED IN ACCORDANCE WITH PRODUCT APPROVALS; SEE MIAMI-DADE COUNTY NOTICE OF ACCEPTANCE OR FLORIDA BUILDING CODE APPROVAL
5. SEE SPECIFICATIONS FOR ADDITIONAL INFORMATION.

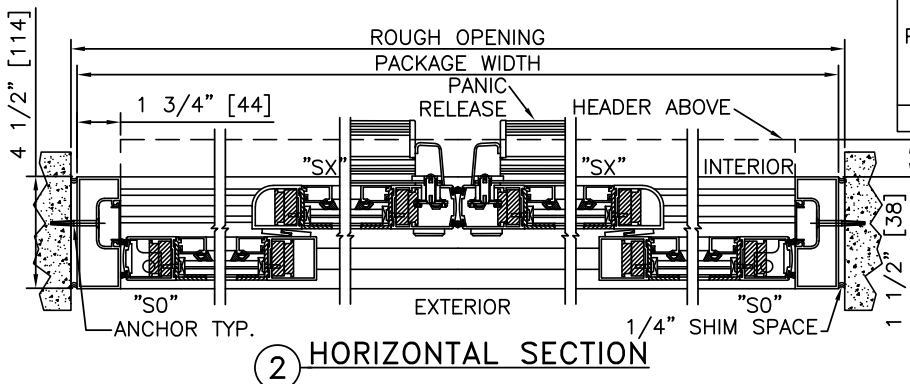

MAX. PACKAGE DIMENSIONS (NARROW STILE)				
PACKAGE WIDTH	NOMINAL CLEAR DOOR OPENING	SX DOOR PANEL NOMINAL WIDTH	SO DOOR PANEL NOMINAL WIDTH	EMERGENCY BREAKOUT NOM. WIDTH
192"	82.3"	48.5"	48.1"	177.5"

DESIGN RATINGS	
MISSILE IMPACT RATING	
<input checked="" type="checkbox"/>	LARGE MISSILE IMPACT
<input checked="" type="checkbox"/>	IMPACT, 50 FT/S, "LEVEL D"
DESIGN PRESSURE RATING (PSF[Pa])	
POSITIVE	80 PSF [3830 Pa]
NEGATIVE	80 PSF [3830 Pa]

**DURA-STORM
3000
"LEVEL D"
IMPACT SERIES**

BI-PARTING WITH AUTOMATIC LOCKING

PROJECT INFORMATION

PROJECT NAME:

LOCATION:

DOOR NUMBER(S):

DATE:

SHEET: OF

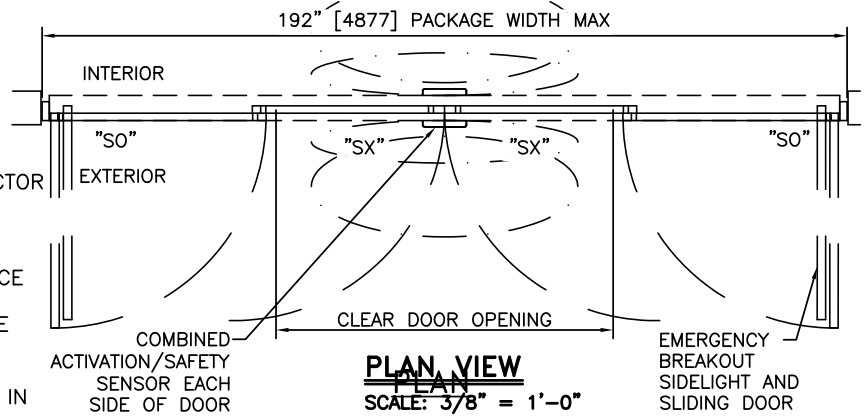
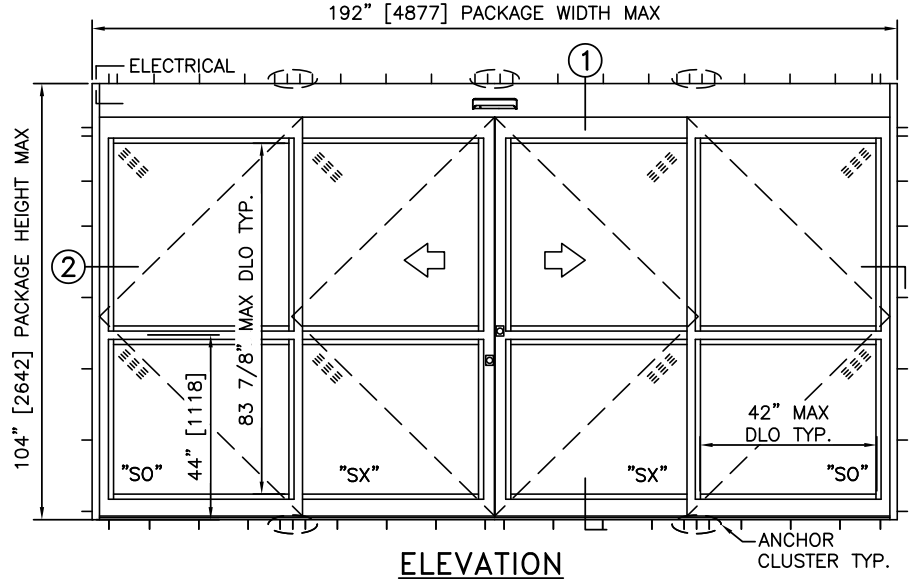
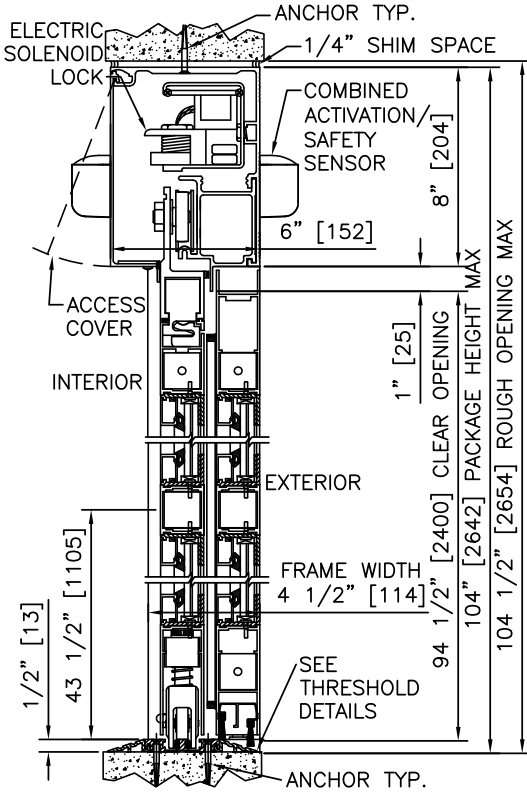

NOTES

1. ELECTRICAL REQUIREMENTS: BY ELECTRICAL CONTRACTOR
 - 1.1. 120 VAC, 5 AMP MIN TO POWER OPERATOR.
 - 1.2. CONTROL CIRCUIT FROM SECURE ACTIVATION TO OPERATOR.
2. ROUGH OPENING SHALL PROVIDE 1/4"[6] SHIM SPACE ON SIDES AND TOP OF PACKAGE.
3. ACTIVATION AND SAFETY ZONES ARE FOR REFERENCE ONLY; SEE ANSI/BHMA A156.10 FOR DETAILED REQUIREMENTS.
4. PRODUCT SHALL BE MANUFACTURED AND INSTALLED IN ACCORDANCE WITH PRODUCT APPROVALS; SEE MIAMI-DADE COUNTY NOTICE OF ACCEPTANCE OR FLORIDA BUILDING CODE APPROVAL
5. SEE SPECIFICATIONS FOR ADDITIONAL INFORMATION.

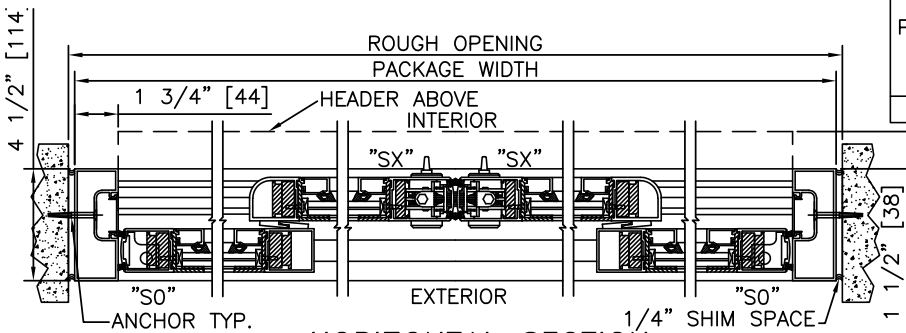

2 HORIZONTAL SECTION

MAX. PACKAGE DIMENSIONS (NARROW STILE)				
PACKAGE WIDTH	NOMINAL CLEAR DOOR OPENING	SX DOOR PANEL NOMINAL WIDTH	SO DOOR PANEL NOMINAL WIDTH	EMERGENCY BREAKOUT NOM. WIDTH
192"	82.3"	48.5"	48.1"	177.5"

DESIGN RATINGS	
MISSILE IMPACT RATING	
<input checked="" type="checkbox"/>	LARGE MISSILE IMPACT
<input checked="" type="checkbox"/>	IMPACT, 50 FT/S, "LEVEL D"
DESIGN PRESSURE RATING (PSF[Pa])	
POSITIVE	80 PSF [3830 Pa]
NEGATIVE	80 PSF [3830 Pa]

**DURA-STORM
3000
"LEVEL D"
IMPACT SERIES**

BI-PARTING WITH PANIC RELEASE & AUTOMATIC LOCKING

PROJECT INFORMATION

PROJECT NAME:

LOCATION:

DOOR NUMBER(S):

DATE:

SHEET: OF

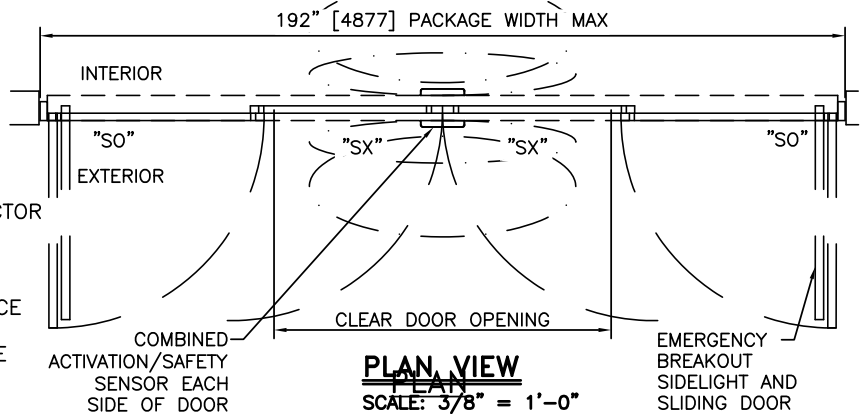
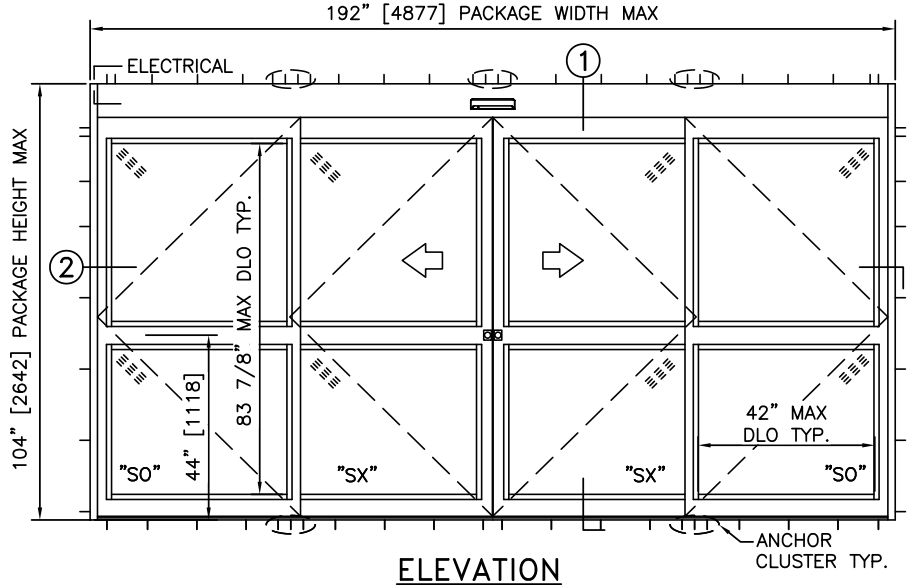
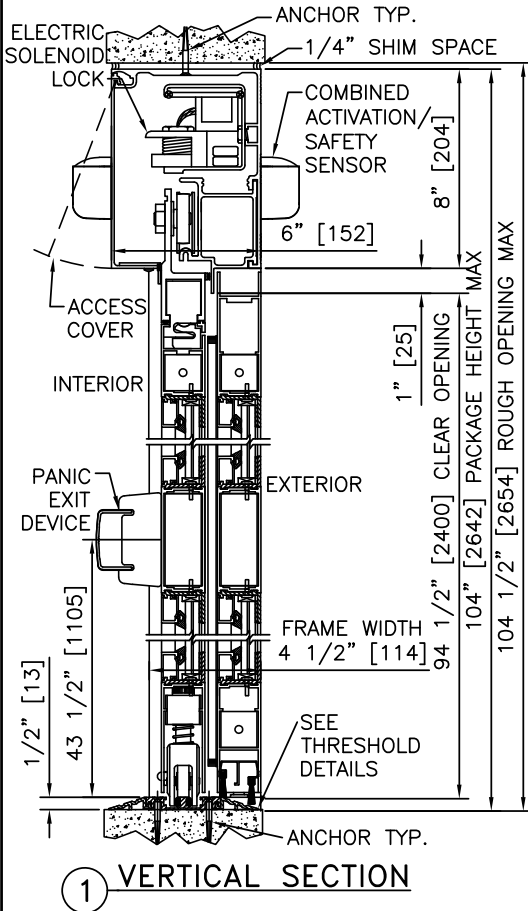

NOTES

- ELECTRICAL REQUIREMENTS: BY ELECTRICAL CONTRACTOR
 - 120 VAC, 5 AMP MIN TO POWER OPERATOR.
 - CONTROL CIRCUIT FROM SECURE ACTIVATION TO OPERATOR.
- ROUGH OPENING SHALL PROVIDE 1/4"[6] SHIM SPACE ON SIDES AND TOP OF PACKAGE.
- ACTIVATION AND SAFETY ZONES ARE FOR REFERENCE ONLY; SEE ANSI/BHMA A156.10 FOR DETAILED REQUIREMENTS.
- PRODUCT SHALL BE MANUFACTURED AND INSTALLED IN ACCORDANCE WITH PRODUCT APPROVALS; SEE MIAMI-DADE COUNTY NOTICE OF ACCEPTANCE OR FLORIDA BUILDING CODE APPROVAL
- SEE SPECIFICATIONS FOR ADDITIONAL INFORMATION.

MAX. PACKAGE DIMENSIONS (NARROW STILE)				
PACKAGE WIDTH	NOMINAL CLEAR DOOR OPENING	SX DOOR PANEL NOMINAL WIDTH	SO DOOR PANEL NOMINAL WIDTH	EMERGENCY BREAKOUT NOM. WIDTH
192"	82.3"	48.5"	48.1"	177.5"

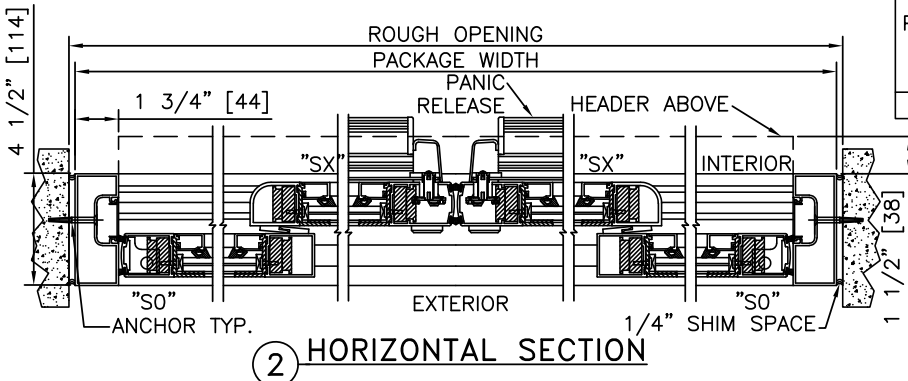

DESIGN RATINGS	
MISSILE IMPACT RATING	
<input checked="" type="checkbox"/>	LARGE MISSILE IMPACT
<input checked="" type="checkbox"/>	IMPACT, 50 FT/S, "LEVEL D"
DESIGN PRESSURE RATING (PSF[Pa])	
POSITIVE	80 PSF [3830 Pa]
NEGATIVE	80 PSF [3830 Pa]