

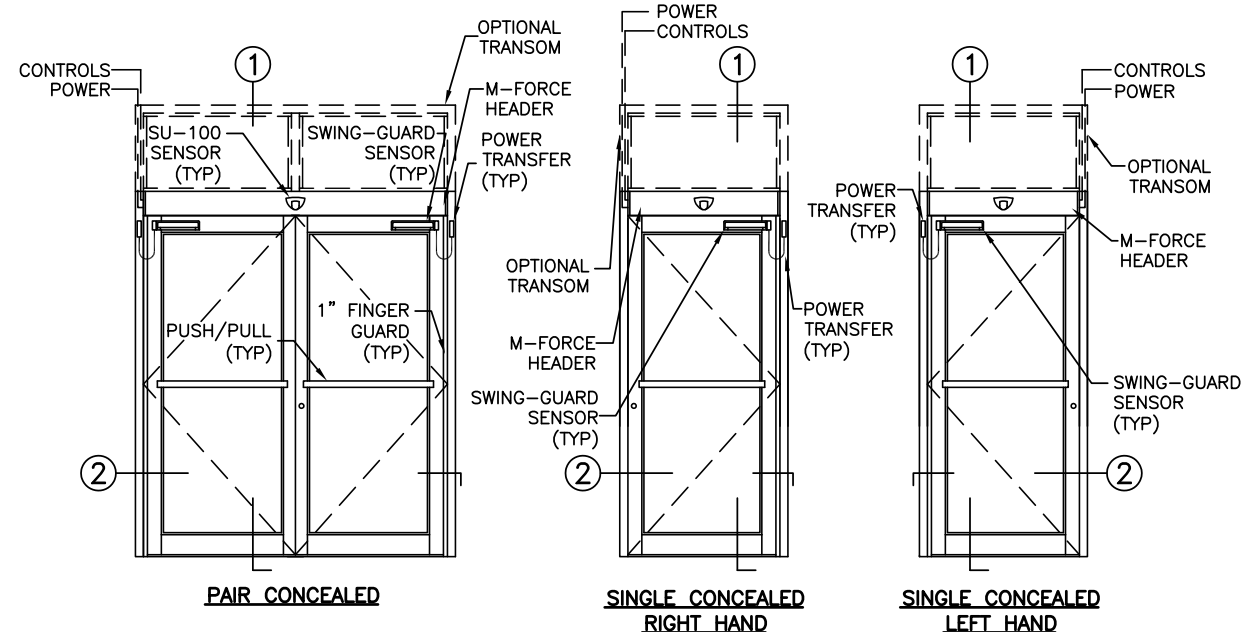

SWING-GUARD® ENTRANCES

FULL ENERGY ENTRANCE WITH DOOR & M-FORCE	
PROJECT INFORMATION	
PROJECT NAME:	
LOCATION:	
DOOR NUMBER(S):	
DATE:	SHEET: OF



ELEVATIONS
SCALE: 1/4" = 1'-0"

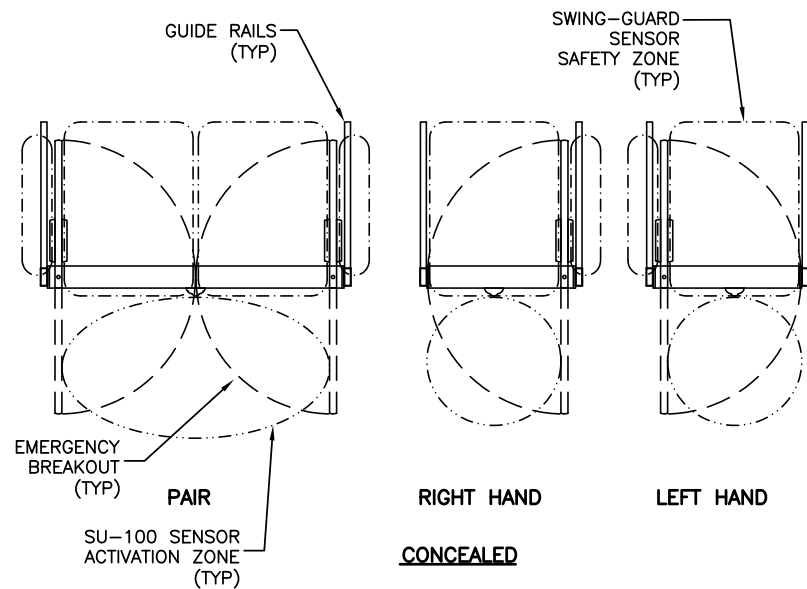

PLAN VIEWS
SCALE: 1/4" = 1'-0"

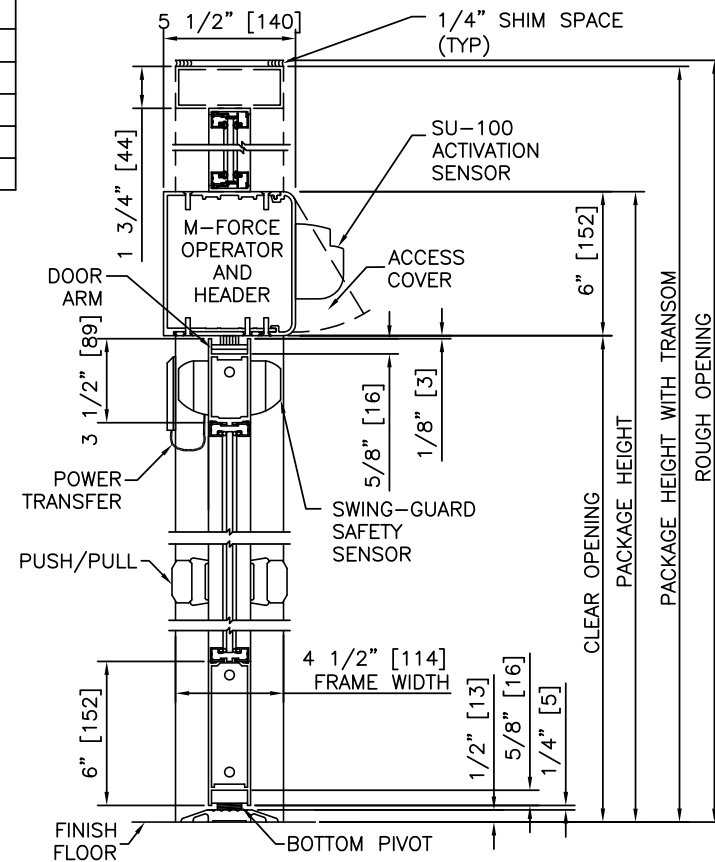

1 VERTICAL SECTION
SCALE: 1 1/2" = 1'-0"

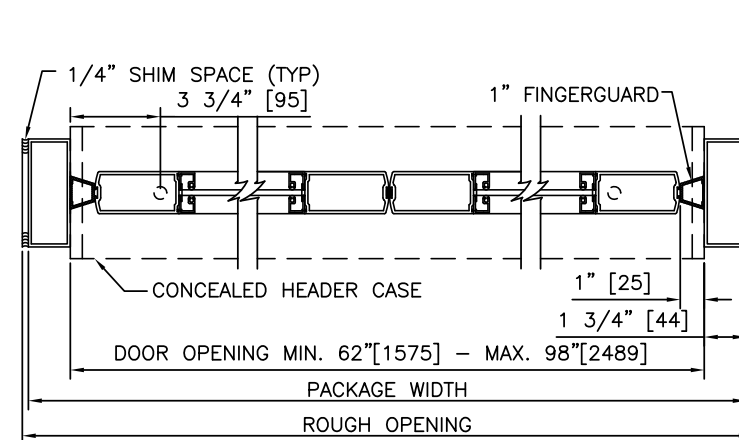

2 HORIZONTAL SECTIONS
SCALE: 1 1/2" = 1'-0"

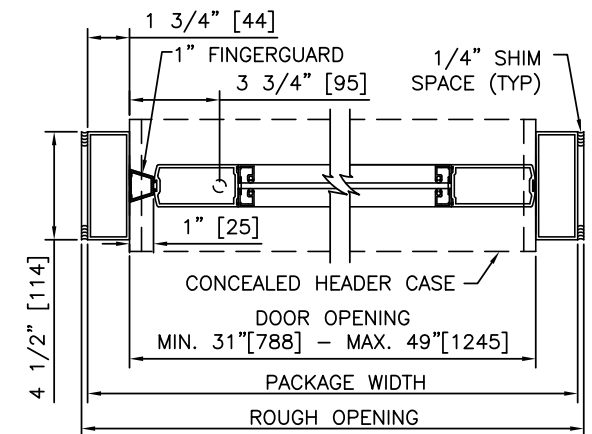

2 HORIZONTAL SECTIONS
SCALE: 1 1/2" = 1'-0"

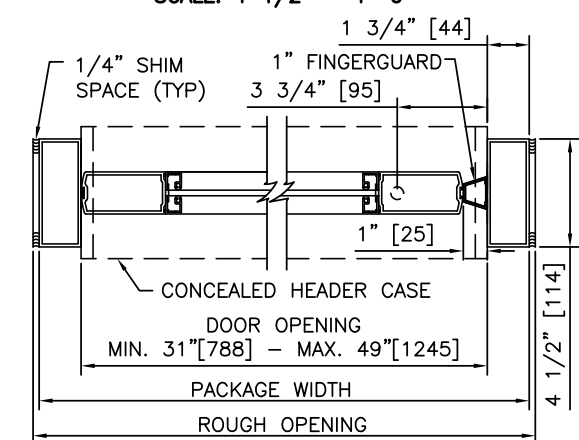

SINGLE CONCEALED

FULL ENERGY ENTRANCE WITH DOOR & M-FORCE

SWING-GUARD® ENTRANCES



- PRODUCT OPTIONS**
- TRANSOM
 YES
 VERTICALS 1 2 3
- FINISH
 ANODIZED CLEAR CL2
 ANODIZED DK BRONZE
 CUSTOM
- LOCKING
 1-POINT
 2-POINT
 3-POINT
- STILES
 NARROW
 MEDIUM
- BOTTOM RAILS
 STANDARD 6"
 OPTIONAL 8" 10" 12"
- THRESHOLDS
 SQ/BVL (EXT)
 SQ/BVL (INT)
 DBL BVL
 RECESSED
- OTHER OPTIONS
 ARMORED STRIKE

- NOTES**
- ELECTRICAL REQUIREMENTS: BY ELECTRICAL CONTRACTOR
 - 120 VAC, 5 AMP MIN TO OPERATOR.
 - CONTROL CIRCUIT FROM ACTIVATION TO OPERATOR.
 - STANDARD GLAZING STOPS FOR ALL PANELS ARE 1/4"[6]; 5/8"[16] AND 1"[25] AVAILABLE.
 - STANDARD STILES, AND BOTTOM RAILS; NARROW STILES, BOTTOM RAILS TO 12"[305], AND MUNTINS AVAILABLE.
 - DOORS MUST BE UN-LATCHED FOR PROPER OPERATION. PROVIDE TIME DELAY RELAY WHEN REQUIRED FOR PROPER OPERATION.
 - LIMITS OF ACTIVATION AND SAFETY ZONES ARE PROVIDED FOR REFERENCE ONLY; SEE ANSI/BHMA A156.10 FOR SPECIFIC REQUIREMENTS.
 - OPERATOR AND INSTALLATION TO COMPLY WITH ANSI/BHMA A156.10.
 - SEE SPECIFICATIONS FOR ADDITIONAL INFORMATION.

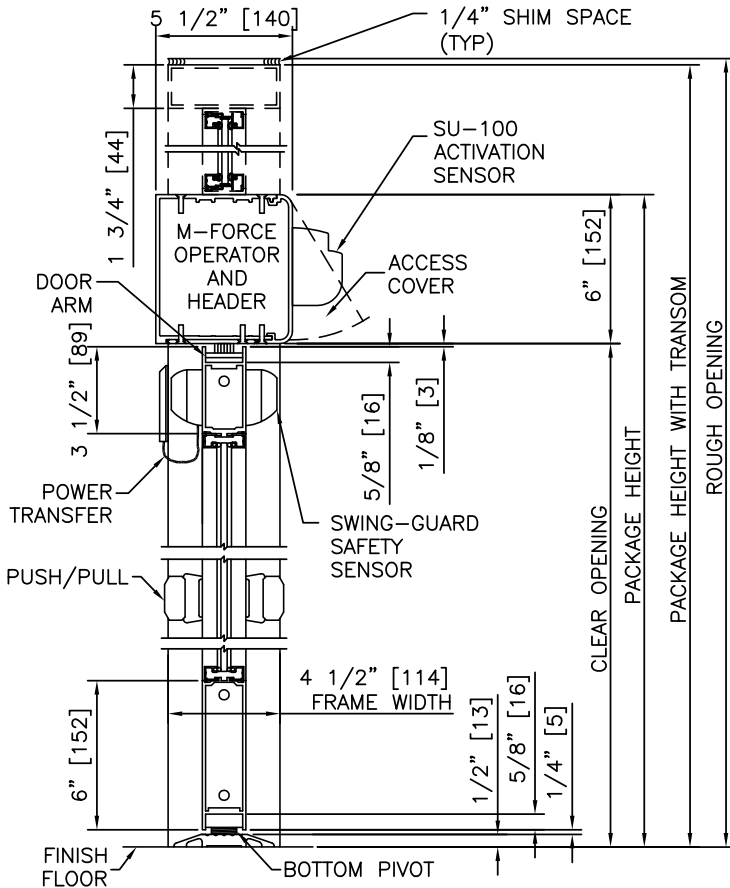

1 VERTICAL SECTION

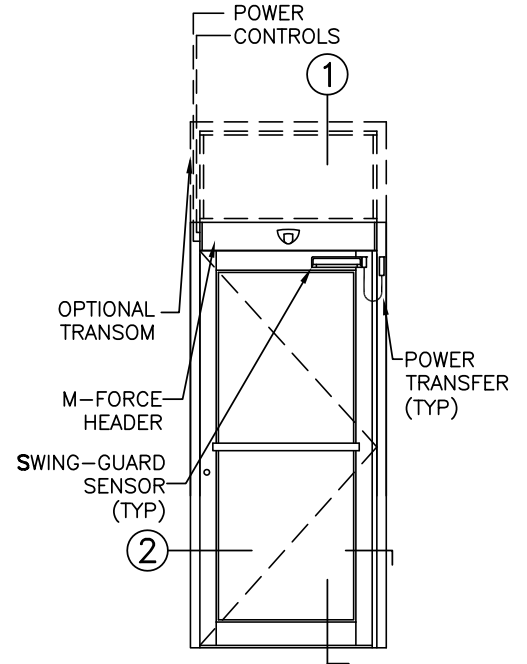

ELEVATION

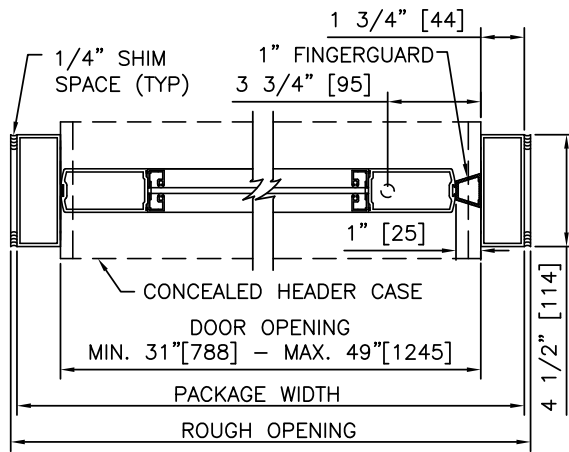

2 HORIZONTAL SECTION

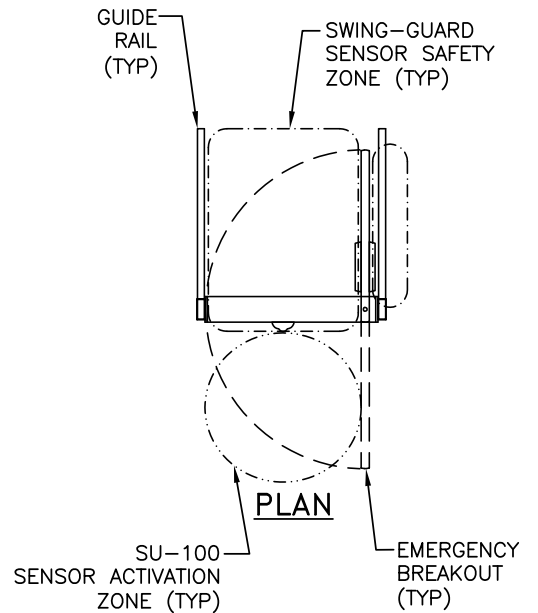

NOTES

1. DETAILS NOT TO SCALE.
2. ELECTRICAL REQUIREMENTS: BY ELECTRICAL CONTRACTOR
 - 2.1. 120 VAC, 5 AMP MIN TO OPERATOR.
 - 2.2. CONTROL CIRCUIT FROM ACTIVATION TO OPERATOR.
3. STANDARD GLAZING STOPS FOR ALL PANELS ARE 1/4"[6]; 5/8"[16] AND 1"[25] AVAILABLE.
4. STANDARD STILES, AND BOTTOM RAILS SHOWN; NARROW STILES, BOTTOM RAILS TO 12"[305], AND MUNTINS AVAILABLE.
5. DOORS MUST BE UN-LATCHED FOR PROPER OPERATION. PROVIDE TIME DELAY RELAY WHEN REQUIRED FOR PROPER OPERATION.
6. LIMITS OF ACTIVATION AND SAFETY ZONES ARE PROVIDED FOR REFERENCE ONLY; SEE ANSI/BHMA A156.10 FOR SPECIFIC REQUIREMENTS.
7. OPERATOR AND INSTALLATION TO COMPLY WITH ANSI/BHMA A156.10.
8. SEE SPECIFICATIONS FOR ADDITIONAL INFORMATION.

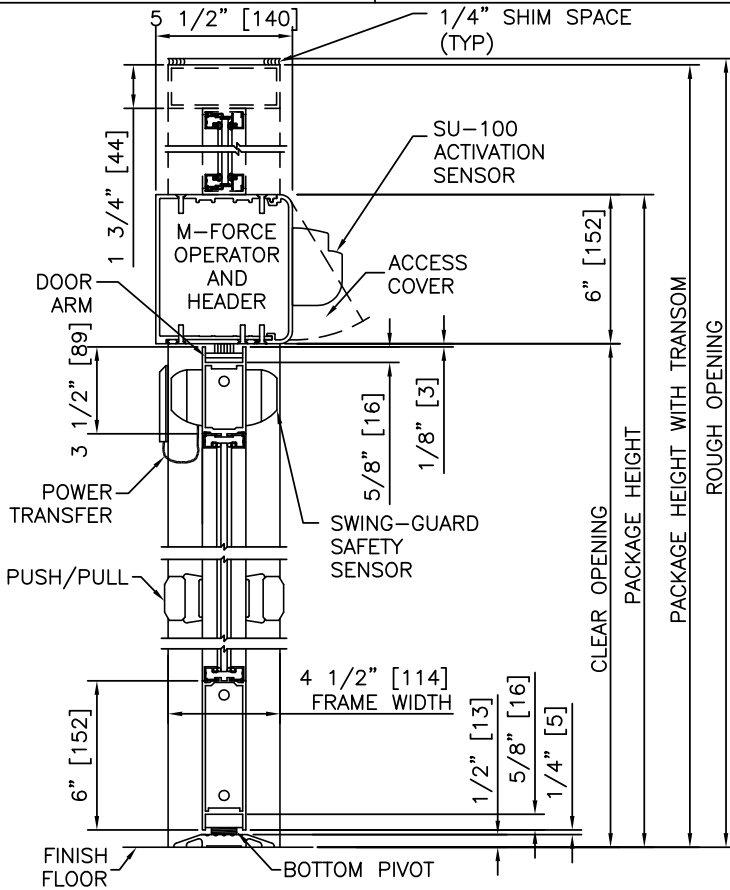

1 VERTICAL SECTION

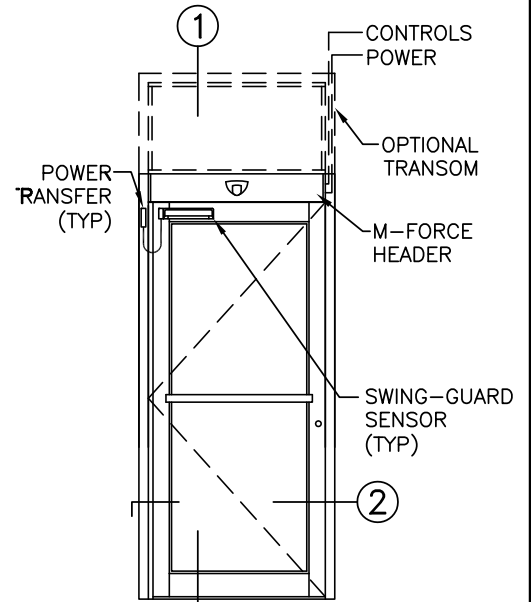

ELEVATION

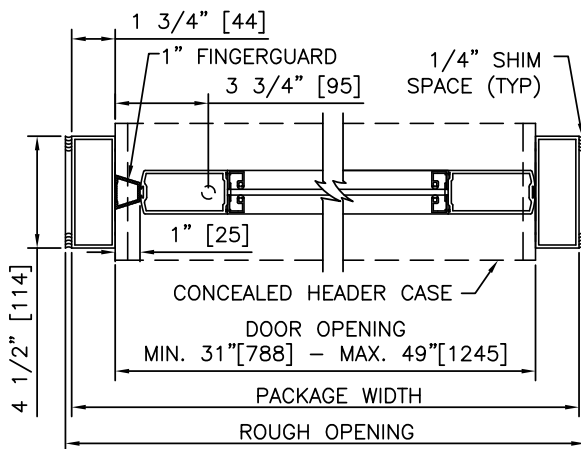
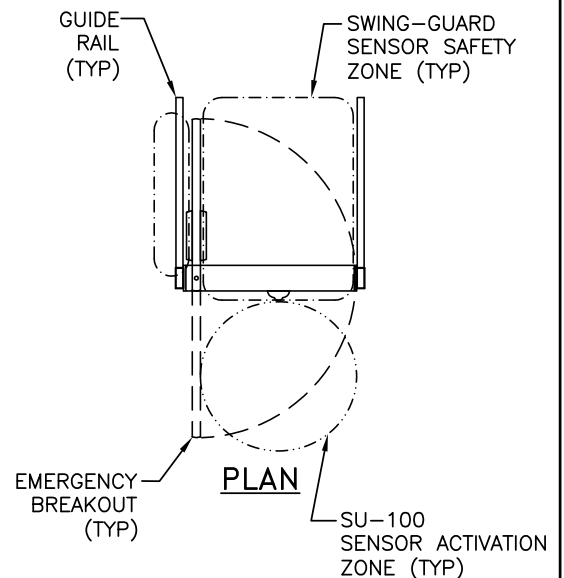

2 HORIZONTAL SECTION

- NOTES**
1. DETAILS NOT TO SCALE.
 2. ELECTRICAL REQUIREMENTS: BY ELECTRICAL CONTRACTOR
 - 2.1. 120 VAC, 5 AMP MIN TO OPERATOR.
 - 2.2. CONTROL CIRCUIT FROM ACTIVATION TO OPERATOR.
 3. STANDARD GLAZING STOPS FOR ALL PANELS ARE 1/4"[6]; 5/8"[16] AND 1"[25] AVAILABLE.
 4. STANDARD STILES, AND BOTTOM RAILS SHOWN; NARROW STILES, BOTTOM RAILS TO 12"[305], AND MUNTINS AVAILABLE.
 5. DOORS MUST BE UN-LATCHED FOR PROPER OPERATION. PROVIDE TIME DELAY RELAY WHEN REQUIRED FOR PROPER OPERATION.
 6. LIMITS OF ACTIVATION AND SAFETY ZONES ARE PROVIDED FOR REFERENCE ONLY; SEE ANSI/BHMA A156.10 FOR SPECIFIC REQUIREMENTS.
 7. OPERATOR AND INSTALLATION TO COMPLY WITH ANSI/BHMA A156.10.
 8. SEE SPECIFICATIONS FOR ADDITIONAL INFORMATION.

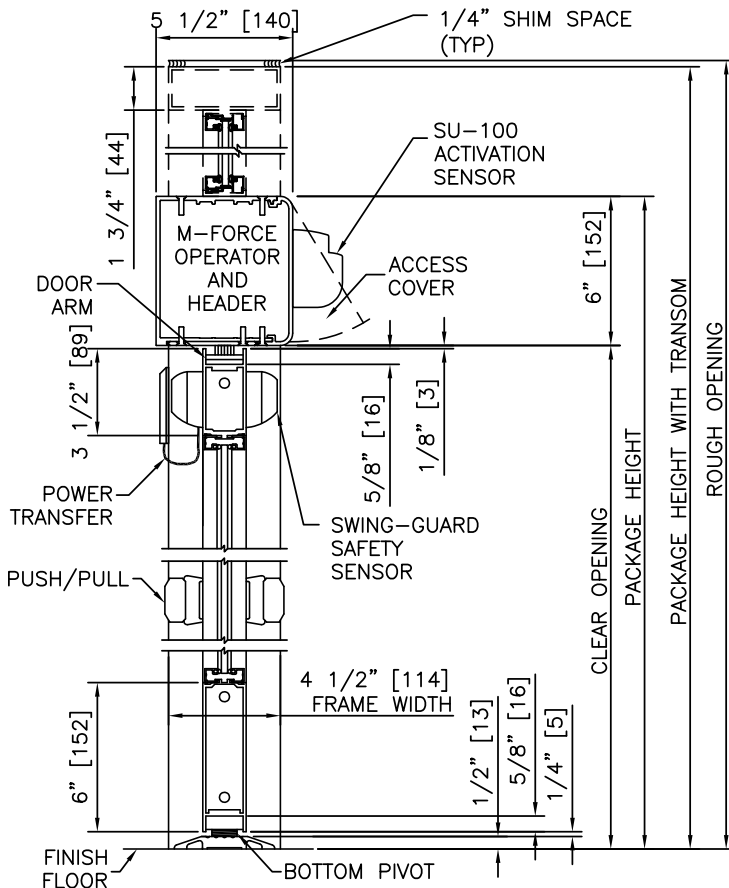

① VERTICAL SECTION

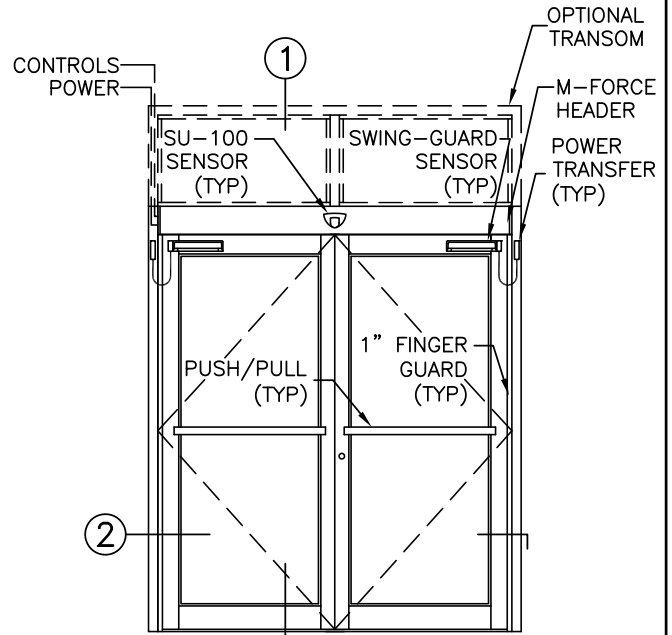

ELEVATION

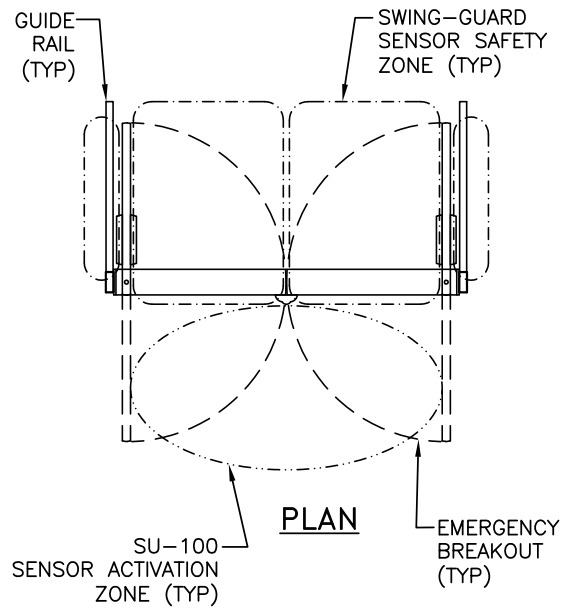

PLAN

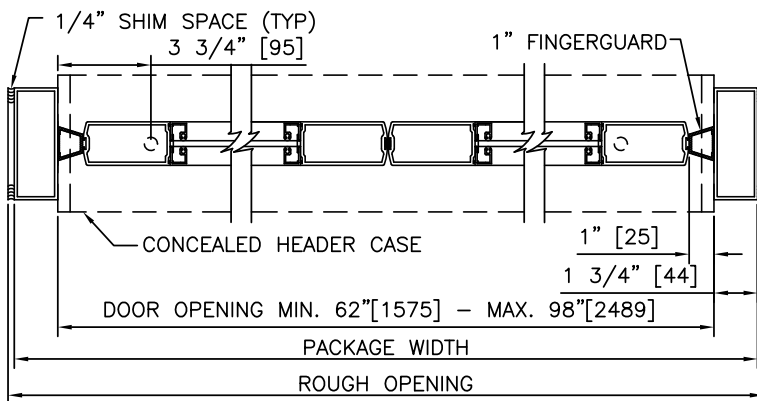

② HORIZONTAL SECTION

- NOTES**
1. DETAILS NOT TO SCALE.
 2. ELECTRICAL REQUIREMENTS: BY ELECTRICAL CONTRACTOR
 - 2.1. 120 VAC, 5 AMP MIN TO OPERATOR.
 - 2.2. CONTROL CIRCUIT FROM ACTIVATION TO OPERATOR.
 3. STANDARD GLAZING STOPS FOR ALL PANELS ARE 1/4"[6]; 5/8"[16] AND 1"[25] AVAILABLE.
 4. STANDARD STILES, AND BOTTOM RAILS SHOWN; NARROW STILES, BOTTOM RAILS TO 12"[305], AND MUNTINS AVAILABLE.
 5. DOORS MUST BE UN-LATCHED FOR PROPER OPERATION. PROVIDE TIME DELAY RELAY WHEN REQUIRED FOR PROPER OPERATION.
 6. LIMITS OF ACTIVATION AND SAFETY ZONES ARE PROVIDED FOR REFERENCE ONLY; SEE ANSI/BHMA A156.10 FOR SPECIFIC REQUIREMENTS.
 7. OPERATOR AND INSTALLATION TO COMPLY WITH ANSI/BHMA A156.10.
 8. SEE SPECIFICATIONS FOR ADDITIONAL INFORMATION.